

FAG



LOCKNUT-DOUBLEHOOK

Double hook wrenches
User manual

SCHAEFFLER

Contents

	Page
About the user manual	
Symbols	2
Availability	2
Legal guidelines	2
Original user manual.....	2
General safety guidelines	
Usage for the intended purpose	3
Usage not for the intended purpose	3
Qualified personnel	3
Hazards	3
Protective equipment.....	3
Safety specifications.....	4
Scope of delivery	
.....	5
Accessories	6
Damage during transit.....	6
Defects	6
Description	
Overview	7
Function	8
Operation	
Preparation.....	9
Mounting of parts	14
Locating the shaft	15
Setting of clearance	15
Decommissioning	
.....	20
Maintenance	
Maintenance plan	21
Disposal	
Regulations	21
Technical data and accessories	
.....	22
Appendix	
Conversion	23

Double hook wrenches

About the user manual

This user manual is part of the device and contains important information.

Symbols

The warning and hazard symbols are defined in accordance with ANSI Z535.6-2006.



In case of non-compliance, death or serious injury may occur. <

NOTICE

In case of non-compliance, damage or malfunctions in the product or the adjacent construction will occur. <

Availability

This user manual is supplied with each device and can also be ordered retrospectively.

NOTICE

Damage to the bearing to be mounted since information that is important for correct adjustment is missing as a result of a user manual that is incomplete, illegible or missing.

As the safety coordinator, you must ensure that this user manual is always complete and legible and that any persons using the device have the user manual available. <

Legal guidelines

The information in this manual corresponded to the most recent status at the close of editing. The illustrations and descriptions cannot be used as grounds for any claims relating to devices that have already been delivered. Schaeffler Technologies AG & Co. KG accepts no liability for any damage or malfunctions if the device or accessories have been modified or used in an inappropriate manner.

Original user manual

The original user manual is taken to be a user manual in the German language. A user manual in another language is to be taken as a translation of the original user manual.

General safety guidelines

It describes how the device may be used, who may use the device and what must be observed when using the device.

Usage for the intended purpose

A double hook wrench with a torque wrench and mounting lever is used for its intended purpose when it is used to set radial internal clearance during the mounting of self-aligning ball bearings and spherical roller bearings with a tapered inner ring on an adapter sleeve.

Usage not for the intended purpose

The torque wrench must not be used to loosen tightened connections. It must not be used as an impact tool.

Usage not for the intended purpose can lead to injury or damage.

Qualified personnel

The double hook wrench, torque wrench and mounting lever may only be used by qualified personnel.

A person defined as qualified personnel:

- has all the necessary knowledge
- is aware of all the hazards and safety guidelines
- has been authorised to use the double hook wrench, torque wrench and mounting lever by the safety co-ordinator
- has fully read and understood this user manual.

Hazards

If a tool is damaged, it may break when subjected to load.

For this reason, only an undamaged tool may be used and repairs to the tool are prohibited.

Protective equipment

Personal protective equipment is intended to protect operating personnel against health hazards. This comprises safety shoes, safety gloves and protective goggles and these must be used in the interests of personal safety.

Double hook wrenches

Safety specifications	The following safety specifications must be observed when using the double hook wrench, torque wrench and mounting lever. Further guidelines on hazards and specific operating procedures can be found, for example, in section <i>Operation</i> , page 9.
Transport	If the ambient conditions during transport of the tool differ to a large extent from the ambient conditions specified for its use, the tool must not be used immediately.
Storage	<p>The double hook wrench, torque wrench and mounting lever must always be stored under the ambient conditions described.</p> <p>These ambient conditions are as follows:</p> <ul style="list-style-type: none">■ humidity max. 90%, non-condensing■ no aggressive chemicals in the environment■ temperature from +5 °C to +40 °C. <p>Unsuitable ambient conditions may result in corrosion of the double hook wrench, torque wrench and mounting lever.</p>
Operation	<p>The double hook wrench, torque wrench and mounting lever may only be used under the ambient conditions described.</p> <p>These ambient conditions are as follows:</p> <ul style="list-style-type: none">■ humidity max. 70%, non-condensing■ no aggressive chemicals in the environment■ temperature from +15 °C to +25 °C■ brightness at least 500 Lux. <p>Unsuitable ambient conditions may result in health hazards to the operating personnel.</p> <p>Only original replacement parts may be used.</p>
Maintenance	Regular maintenance must be carried out on the torque wrench.
Disposal	Locally applicable regulations must be observed.
Conversion	The double hook wrench, torque wrench and mounting lever must not be converted.

Scope of delivery

The scope of delivery comprises the double hook wrench, torque wrench, mounting lever, transport case, mounting paste and user manual, see *table* and *Figure 1* as well as *table* and *Figure 2*, page 6.

Scope of delivery Double hook wrench set LOCKNUT-DOUBLEHOOK-KM3-8-SET

Component	Designation	m ¹⁾ kg
Torque wrench	LOCKNUT-DOUBLEHOOK.WRENCH10-50NM	1,1
Double hook wrench	LOCKNUT-DOUBLEHOOK-KM3-D16	0,2
	LOCKNUT-DOUBLEHOOK-KM4-D16	0,2
	LOCKNUT-DOUBLEHOOK-KM5-D16	0,2
	LOCKNUT-DOUBLEHOOK-KM6-D16	0,2
	LOCKNUT-DOUBLEHOOK-KM7-D16	0,2
	LOCKNUT-DOUBLEHOOK-KM8-D16	0,3
Mounting lever	LOCKNUT-DOUBLEHOOK.LEVER400	0,8
Transport case	LOCKNUT-DOUBLEHOOK.CASE-KM3-8	3
Mounting paste	ARCANOL-MOUNTINGPASTE-70G	0,1
User manual	MATNR 032821409-0000	–

1) Mass.

- ① Torque wrench WRENCH10-50NM
- ② Double hook wrench KM3
- ③ Double hook wrench KM4
- ④ Double hook wrench KM5
- ⑤ Double hook wrench KM6
- ⑥ Double hook wrench KM7
- ⑦ Double hook wrench KM8
- ⑧ Mounting lever
- ⑨ Transport case
- ⑩ Mounting paste
- ⑪ User manual

Figure 1
Scope of delivery
Double hook wrench set KM3-8



Double hook wrenches

Scope of delivery Double hook wrench set LOCKNUT -DOUBLEHOOK-KM9-15-SET

Component	Designation	m ¹⁾ kg
Torque wrench	LOCKNUT-DOUBLEHOOK.WRENCH20-100NM	2,3
Adapter	LOCKNUT-DOUBLEHOOK.WRENCH-ADAPTER22-16	0,1
Double hook wrench	LOCKNUT-DOUBLEHOOK-KM9-D22	0,4
	LOCKNUT-DOUBLEHOOK-KM10-D22	0,4
	LOCKNUT-DOUBLEHOOK-KM11-D22	0,4
	LOCKNUT-DOUBLEHOOK-KM12-D22	0,4
	LOCKNUT-DOUBLEHOOK-KM13-D22	0,4
	LOCKNUT-DOUBLEHOOK-KM14-D22	0,4
Mounting lever	LOCKNUT-DOUBLEHOOK.LEVER400	0,8
Transport case	LOCKNUT-DOUBLEHOOK.CASE-KM9-15	3
Mounting paste	ARCANOL-MOUNTINGPASTE-70G	0,1
User manual	MATNR 032821409-0000	-

1) Mass.

- ① Torque wrench WRENCH20-100NM
- ② Adapter
- ③ Double hook wrench KM9
- ④ Double hook wrench KM10
- ⑤ Double hook wrench KM11
- ⑥ Double hook wrench KM12
- ⑦ Double hook wrench KM13
- ⑧ Double hook wrench KM14
- ⑨ Double hook wrench KM15
- ⑩ Mounting lever
- ⑪ Transport case
- ⑫ Mounting paste
- ⑬ User manual

Figure 2
Scope of delivery
Double hook wrench set KM9-15



Accessories

Individual parts are supplied without accessories. For accessories such as mounting paste, see section *Technical data and accessories*, page 22.

Damage during transit

Any damage during transit must be reported as a complaint to the carrier.

Defects

Any defects must be reported promptly to Schaeffler Technologies AG & Co. KG.

Description

The method described in this manual, in conjunction with the appropriate tool, can be used to achieve precise setting of the radial internal clearance of self-aligning ball bearings and spherical roller bearings without the need to measure the radial internal clearance.

Overview

Reduction of the radial internal clearance requires the use of a double hook wrench, torque wrench and mounting lever, *Figure 3*.

- ① Double hook wrench
- ② Marking of torsion angle
- ③ Hole for locking pin
- ④ Torque wrench
- ⑤ Adapter
- ⑥ Locking pin
- ⑦ Mounting lever



Figure 3
Tool

Double hook wrench

This is made from steel and is marked with values for standardised torsion angles.

Torque wrench

This is made from steel and plastic and must be subjected to regular maintenance.

Adapter

This is made from steel and is used to change the locating diameter. The adapter is supplied already fitted to the torque wrench WRENCH20-100NM.

Mounting lever

This is made from steel and can be inserted in the double hook wrench in the same way as the torque wrench.

Double hook wrenches

Function

Measurement of the radial internal clearance is difficult especially in the case of smaller self-aligning ball bearings and spherical roller bearings. If the bearing is fitted in a housing, it is not possible to measure the radial internal clearance in some cases.

As a result, measurement is often dispensed with and the radial internal clearance is estimated in approximate terms by means of the method normally used in the past. In this case, the rolling bearing is pressed onto the adapter sleeve until the outer ring can still be freely rotated and slight resistance is felt under swivelling.

With the method we recommend, the radial internal clearance can be set very accurately. The radial internal clearance is reduced in two stages, *Figure 4*. First, the locknut is lightly tightened to a specified tightening torque. This gives a precisely defined initial position and the radial internal clearance is then set very accurately in the second stage.

The locknut is then tightened by a defined angle. The radial internal clearance has now been reduced by the recommended 60% to 70%.

- ① Housing
- ② Self-aligning ball bearing
- ③ Adapter sleeve
- ④ Locknut
- ⑤ Double hook wrench
- ⑥ Torque wrench
- ⑦ Mounting lever
- ⑧ Radial internal clearance, locknut lightly tightened
- ⑨ Radial internal clearance, locknut completely tightened

Figure 4
Reducing the radial internal clearance

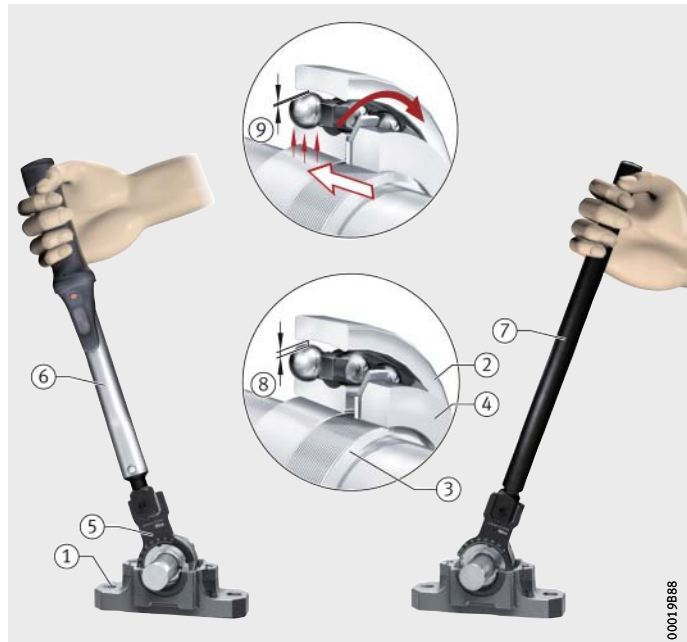

Operation Mounting is carried out at a suitable location:

- sufficiently strong illumination
- ergonomic working height for the fitter.

Preparation The torque wrench may only be used if it has been subjected to correct maintenance, see section *Maintenance*, page 21. Based on the bearing to be mounted, the tool to be used and the tightening torque to be applied can be determined from the tables, see *table*, page 11.

NOTICE

Incorrect friction value due to contamination. This leads to incorrect setting of the bearing radial internal clearance and thus wear of the bearing.

Clean the parts to be mounted thoroughly using a lint-free cloth. <

NOTICE

Damage to the bearing during dismounting if the locknut has cold welded to the adapter sleeve.

Apply a thin coating of mounting paste to the thread of the adapter sleeve, for example using ARCANOL-MOUNTINGPASTE-70G. <

Double hook wrenches

Preparing the tool and parts

Before mounting, the tool and the parts to be mounted must be prepared, *Figure 5*:

- double hook wrench fitted to the torque wrench
- tightening torque set on the torque wrench
- cleaned using a lint-free cloth:
 - bore and end faces of the bearing inner ring,
 - the part of the shaft on which the adapter sleeve will be mounted, adapter sleeve
- thin coating of mounting paste applied to the thread of the adapter sleeve.

NOTICE

Danger of injury if the double hook wrench becomes detached from the torque wrench or mounting lever.

Ensure that the locking pin fully engages when the double hook wrench is attached. <

- ① Double hook wrench
- ② Locking pin engaged
- ③ Torque wrench
- ④ Display of tightening torque
- ⑤ Bearing inner ring
- ⑥ Shaft
- ⑦ Adapter sleeve

Figure 5
Tool and parts to be mounted

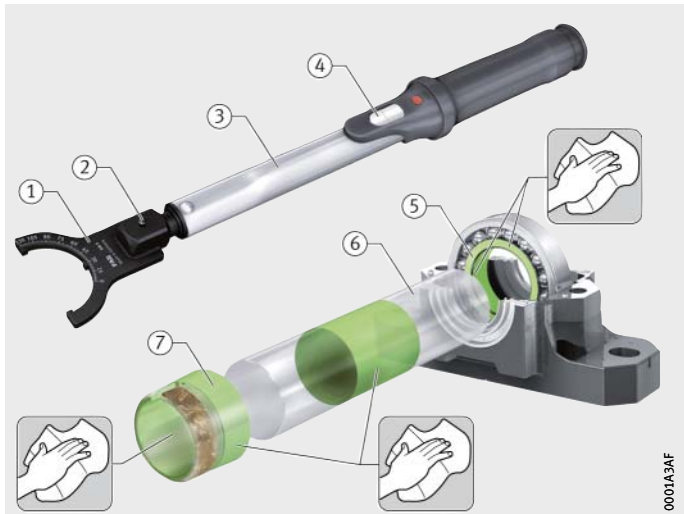

**Self-aligning ball bearings
Tools, values**

Designation	Nut of adapter sleeve	LOCKNUT-DOUBLEHOOK-		Tightening torque Nm	Torsion angle °
		Double hook wrench	Torque wrench		
1203-K	KM3	KM3-D16	WRENCH10-50NM	10	–
2203-K	KM3	KM3-D16	WRENCH10-50NM	10	–
1303-K	KM3	KM3-D16	WRENCH10-50NM	16	–
2303-K	KM3	KM3-D16	WRENCH10-50NM	16	–
1204-K	KM4	KM4-D16	WRENCH10-50NM	14	–
2204-K	KM4	KM4-D16	WRENCH10-50NM	14	–
1304-K	KM4	KM4-D16	WRENCH10-50NM	24	–
2304-K	KM4	KM4-D16	WRENCH10-50NM	24	–
1205-K	KM5	KM5-D16	WRENCH10-50NM	23	–
2205-K	KM5	KM5-D16	WRENCH10-50NM	22	–
1305-K	KM5	KM5-D16	WRENCH10-50NM	42	–
2305-K	KM5	KM5-D16	WRENCH10-50NM	18	30
1206-K	KM6	KM6-D16	WRENCH10-50NM	36	–
2206-K	KM6	KM6-D16	WRENCH10-50NM	34	–
1306-K	KM6	KM6-D16	WRENCH10-50NM	37	30
2306-K	KM6	KM6-D16	WRENCH10-50NM	33	30
1207-K	KM7	KM7-D16	WRENCH10-50NM	34	30
2207-K	KM7	KM7-D16	WRENCH10-50NM	31	30
1307-K	KM7	KM7-D16	WRENCH10-50NM	40	45
2307-K	KM7	KM7-D16	WRENCH10-50NM	49	30
1208-K	KM8	KM8-D16	WRENCH10-50NM	22	60
2208-K	KM8	KM8-D16	WRENCH10-50NM	20	60
1308-K	KM8	KM8-D16	WRENCH10-50NM	41	60
2308-K	KM8	KM8-D16	WRENCH10-50NM	32	60

Double hook wrenches

Self-aligning ball bearings
Tools, values
(continued)

Designation	Nut of adapter sleeve	LOCKNUT-DOUBLEHOOK-		Tightening torque Nm	Torsion angle °
		Double hook wrench	Torque wrench		
1209-K	KM9	KM9-D22	WRENCH20-100NM	27	60
2209-K	KM9	KM9-D22	WRENCH20-100NM	36	60
1309-K	KM9	KM9-D22	WRENCH20-100NM	65	60
2309-K	KM9	KM9-D22	WRENCH20-100NM	57	60
1210-K	KM10	KM10-D22	WRENCH20-100NM	27	60
2210-K	KM10	KM10-D22	WRENCH20-100NM	35	60
1310-K	KM10	KM10-D22	WRENCH20-100NM	77	60
2310-K	KM10	KM10-D22	WRENCH20-100NM	64	60
1211-K	KM11	KM11-D22	WRENCH20-100NM	22	60
2211-K	KM11	KM11-D22	WRENCH20-100NM	21	60
1311-K	KM11	KM11-D22	WRENCH20-100NM	66	60
2311-K	KM11	KM11-D22	WRENCH20-100NM	43	60
1212-K	KM12	KM12-D22	WRENCH20-100NM	45	60
2212-K	KM12	KM12-D22	WRENCH20-100NM	44	60
1312-K	KM12	KM12-D22	WRENCH20-100NM	60	75
2312-K	KM12	KM12-D22	WRENCH20-100NM	70	60
1213-K	KM13	KM13-D22	WRENCH20-100NM	36	75
2213-K	KM13	KM13-D22	WRENCH20-100NM	25	75
1313-K	KM13	KM13-D22	WRENCH20-100NM	92	75
2313-K	KM13	KM13-D22	WRENCH20-100NM	60	75
1214-K	KM14	KM14-D22	WRENCH20-100NM	38	75
2214-K	KM14	KM14-D22	WRENCH20-100NM	47	75
1314-K	KM14	KM14-D22	WRENCH20-100NM	52	90
2314-K	KM14	KM14-D22	WRENCH20-100NM	100	75
1215-K	KM15	KM15-D22	WRENCH20-100NM	59	75
2215-K	KM15	KM15-D22	WRENCH20-100NM	66	75
1315-K	KM15	KM15-D22	WRENCH20-100NM	98	90
2315-K	KM15	KM15-D22	WRENCH20-100NM	75	90

**Spherical roller bearings
Tools, values**

Designation	Nut of adapter sleeve	LOCKNUT-DOUBLEHOOK-		Tightening torque Nm	Torsion angle °
		Double hook wrench	Torque wrench		
21304-K	KM4	KM4-D16	WRENCH10-50NM	24	–
22205-K	KM5	KM5-D16	WRENCH10-50NM	18	30
21305-K	KM5	KM5-D16	WRENCH10-50NM	42	–
22206-K	KM6	KM6-D16	WRENCH10-50NM	33	30
21306-K	KM6	KM6-D16	WRENCH10-50NM	40	30
22306-K	KM6	KM6-D16	WRENCH10-50NM	35	75
22207-K	KM7	KM7-D16	WRENCH10-50NM	24	60
21307-K	KM7	KM7-D16	WRENCH10-50NM	26	60
22307-K	KM7	KM7-D16	WRENCH10-50NM	35	75
22208-K	KM8	KM8-D16	WRENCH10-50NM	34	60
21308-K	KM8	KM8-D16	WRENCH10-50NM	27	75
22308-K	KM8	KM8-D16	WRENCH10-50NM	35	75
22209-K	KM9	KM9-D22	WRENCH20-100NM	51	60
21309-K	KM9	KM9-D22	WRENCH20-100NM	25	90
22309-K	KM9	KM9-D22	WRENCH20-100NM	70	75
22210-K	KM10	KM10-D22	WRENCH20-100NM	62	60
21310-K	KM10	KM10-D22	WRENCH20-100NM	53	90
22310-K	KM10	KM10-D22	WRENCH20-100NM	96	75
22211-K	KM11	KM11-D22	WRENCH20-100NM	44	75
21311-K	KM11	KM11-D22	WRENCH20-100NM	19	90
22311-K	KM11	KM11-D22	WRENCH20-100NM	68	75
22212-K	KM12	KM12-D22	WRENCH20-100NM	38	85
21312-K	KM12	KM12-D22	WRENCH20-100NM	51	90
22312-K	KM12	KM12-D22	WRENCH20-100NM	67	85
22213-K	KM13	KM13-D22	WRENCH20-100NM	82	85
21313-K	KM13	KM13-D22	WRENCH20-100NM	91	90
22313-K	KM13	KM13-D22	WRENCH20-100NM	59	100
22214-K	KM14	KM14-D22	WRENCH20-100NM	62	100
21314-K	KM14	KM14-D22	WRENCH20-100NM	98	100
22314-K	KM14	KM14-D22	WRENCH20-100NM	88	100
22215-K	KM15	KM15-D22	WRENCH20-100NM	87	100
21315-K	KM15	KM15-D22	WRENCH20-100NM	78	115
22315-K	KM15	KM15-D22	WRENCH20-100NM	85	110

Double hook wrenches

Mounting of parts

Once all the parts to be mounted have been cleaned and a thin coating of mounting paste has been applied to the thread of the adapter sleeve, the parts can be mounted.

Inserting and greasing the seals:

- ▶ Press the lower halves of the seals finger tight into the housing and grease the space between the seal lips.
- ▶ Place the shaft at the required position and lift it up.

- ① Housing
- ② Shaft
- ③ Seal, lower half

Figure 6
Seal

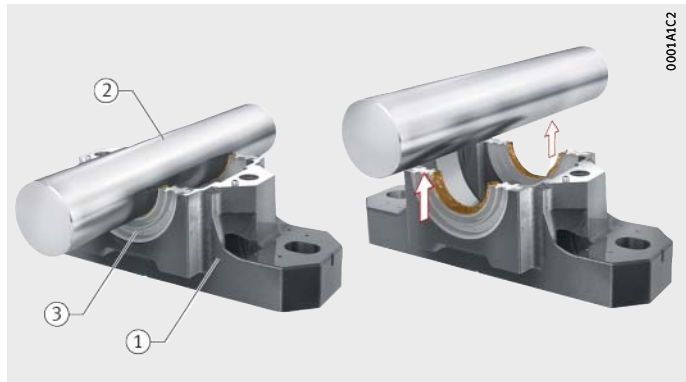

While sliding the bearing onto the shaft, ensure that the adapter sleeve remains at the required position.

Mounting the adapter sleeve and bearing:

- ▶ Slide the adapter sleeve to the required position on the shaft.
- ▶ Slide the bearing onto the adapter sleeve.

- ① Housing
- ② Shaft
- ③ Adapter sleeve
- ④ Required position of adapter sleeve
- ⑤ Bearing

Figure 7
Adapter sleeve and bearing

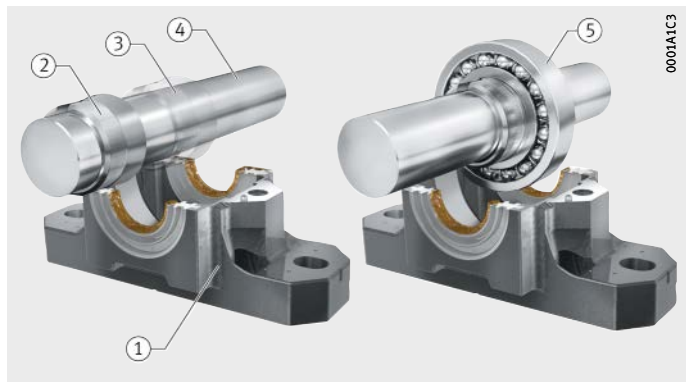

The tab washer should lie against the end face of the bearing inner ring. The locknut should lie lightly against the tab washer.

Mounting the tab washer and locknut:

- ▶ Slide the tab washer onto the adapter sleeve.
- ▶ Screw the locknut onto the adapter sleeve.
- ▶ Lower the shaft.

▷ The bearing and adapter sleeve are mounted. The tab washer and locknut are mounted.

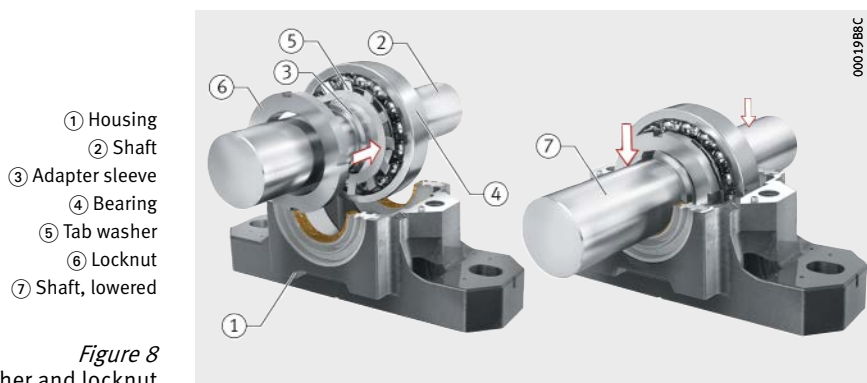

Figure 8

Tab washer and locknut

Locating the shaft

The shaft must not be allowed to rotate during mounting. Before the shaft is located using a suitable retaining device, the corresponding area must be degreased.

Setting the clearance

The following accessories are required:

- retaining device for locating the shaft
- retaining gib for preventing co-rotation of the adapter sleeve
- waterproof felt pen for marking the position on the shaft.

Double hook wrenches

Tightening the locknut to the tightening torque

During tightening, it may be necessary to reposition the double hook wrench several times.

NOTICE

Locknut tightened to the incorrect torque due to incorrect hand position. This leads to incorrect setting of the bearing radial internal clearance and thus increased wear of the bearing.

Use the torque with the correct hand position as shown. The centre of the grip must be located between the ring finger and middle finger. ◀

Tightening the locknut to the tightening torque, *Figure 9*:

- ▶ Locate the adapter sleeve by means of the retaining gib.
- ▶ Tighten the locknut until the torque wrench is released.
- ▷ The locknut is now tightened to the tightening torque.

- ① Adapter sleeve
- ② Retaining gib
- ③ Locknut
- ④ Double hook wrench
- ⑤ Torque wrench
- ⑥ Marking of grip centre
- ⑦ Hand position

Figure 9
Tightening torque

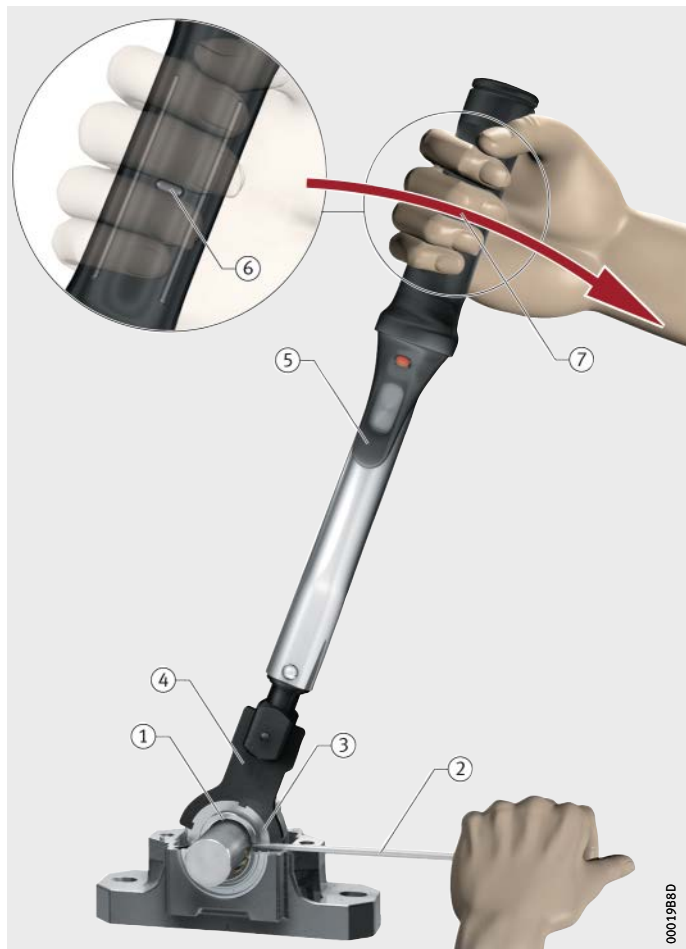

0001861000

Marking of components

Before marking the components, the double hook wrench is removed from the torque wrench. The double hook wrench is then fitted to the mounting lever. The locknut and adapter sleeve are marked before the locknut is tightened by the torsion angle. A waterproof felt pen is highly suitable for applying the marking.

Marking of components, *Figure 10*:

- ▶ Position the double hook wrench.
- ▶ At the mark for the angle 0, draw a line across the end faces of the locknut and the adapter sleeve.
- ▶ At the mark for the torsion angle, draw a line across the end faces of the locknut.
- ▷ The components are marked.



- ① Mark for angle 0
- ② Mark for torsion angle

Figure 10
Marking

Double hook wrenches

Tightening the locknut by the torsion angle

The clearance is set by tightening the locknut by the torsion angle.

Tightening the locknut by the torsion angle, *Figure 11*:

- ▶ Locate the adapter sleeve by means of the retaining gib.
- ▶ Tighten the locknut until the mark for the torsion angle on the locknut and the mark for the angle 0 on the adapter sleeve coincide.
- ▷ The locknut is completely tightened and the clearance is set.

- ① Adapter sleeve
- ② Retaining gib
- ③ Locknut
- ④ Double hook wrench
- ⑤ Mark for angle 0 on adapter sleeve
- ⑥ Mark for torsion angle on locknut

Figure 11
Clearance set

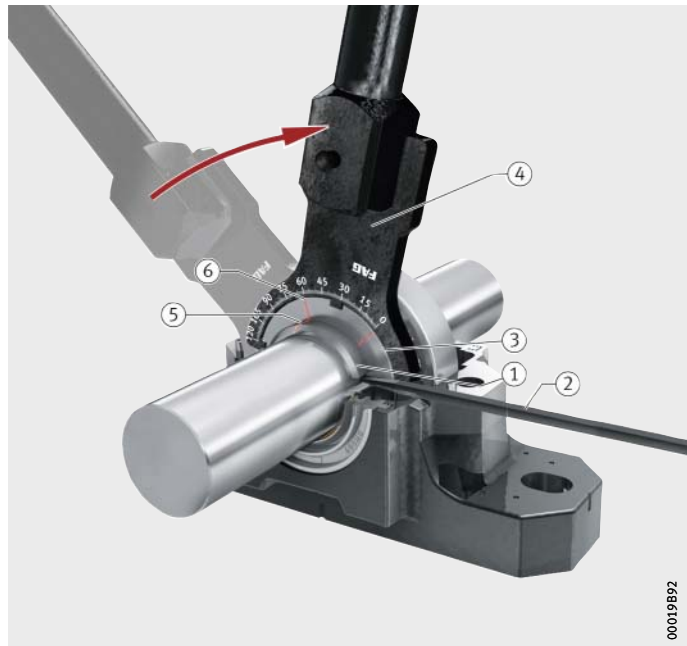

Securing the locknut

The locknut is secured against rotation in order that the clearance set cannot change during operation.

NOTICE

Increased clearance in the bearing due to backwards rotation of the locknut, leading to increased wear of the bearing.

Never loosen the locknut, but tighten it slightly as necessary. ◀

Securing the locknut, *Figure 12*:

- ▶ If there is no tab opposite a slot: tighten the locknut slightly.
- ▶ Bend the tab of the tab washer into the slot in the locknut.
- ▷ The locknut is secured against rotation.



① Tab, bent over

Figure 12
Locknut secured

Double hook wrenches

Decommissioning

If the tool is no longer in use, the double hook wrench is removed from the mounting lever. Grease and any other contaminants should be wiped off the double hook wrench, mounting lever and torque wrench.

NOTICE

Damaged torque wrench due to storage with preload. This leads to incorrect setting of the bearing radial internal clearance and thus increased wear of the bearing.

Set the tightening torque to the value 0, *Figure 13*. ◀



- ① Torque wrench
- ② Tightening torque 0

Figure 13
Decommissioning

All parts should be stored under the specified conditions, see section *Storage*, page 4.

Maintenance The tool must be checked before every use.

NOTICE

Incorrect release of torque wrench due to lack of maintenance. This leads to incorrect setting of the bearing radial internal clearance and thus increased wear of the bearing. Check the torque wrench as stated in the maintenance plan and carry out maintenance as necessary. <

Maintenance plan The maintenance items are stated in the maintenance plan, see *tables*.

Before every use

Subassembly	Activity
Torque wrench	<ul style="list-style-type: none">Visual inspection – check for damageRecord the number of instances of use
Double hook wrench, mounting lever	<ul style="list-style-type: none">Visual inspection – check for damage

As necessary

Subassembly	Activity
Torque wrench	<ul style="list-style-type: none">After 5 000 instances of use, carry out checking, maintenance as necessary and calibration The inspection device to be used must fulfil the requirements in DIN EN ISO 6789:2003

Disposal The tool can be returned to Schaeffler for disposal.

WARNING

Danger of injury due to catapulting of components if the torque wrench is dismantled, since some parts are under spring loading. Wear safety goggles if the torque wrench is to be dismantled. <

Regulations Disposal must be carried out in accordance with locally applicable regulations.

Double hook wrenches

Technical data and accessories

Technical data, standard accessories and special accessories, see *tables*.

Torque wrenches

Designation	Dimensions mm	Mass kg
LOCKNUT-DOUBLEHOOK.WRENCH10-50NM	30×30×330	1,1
LOCKNUT-DOUBLEHOOK.WRENCH20-100NM	40×40×375	2,3

Double hook wrenches

Designation	Dimensions mm	Mass kg
LOCKNUT-DOUBLEHOOK-KM3-D16	111×41×26	0,2
LOCKNUT-DOUBLEHOOK-KM4-D16	111×44×26	0,2
LOCKNUT-DOUBLEHOOK-KM5-D16	111×50×26	0,2
LOCKNUT-DOUBLEHOOK-KM6-D16	111×60×26	0,2
LOCKNUT-DOUBLEHOOK-KM7-D16	111×70×26	0,2
LOCKNUT-DOUBLEHOOK-KM8-D16	112×78×26	0,3
LOCKNUT-DOUBLEHOOK-KM9-D22	117×83×30	0,4
LOCKNUT-DOUBLEHOOK-KM10-D22	117×88×30	0,4
LOCKNUT-DOUBLEHOOK-KM11-D22	117×98×30	0,4
LOCKNUT-DOUBLEHOOK-KM12-D22	117×106×30	0,4
LOCKNUT-DOUBLEHOOK-KM13-D22	117×115×30	0,4
LOCKNUT-DOUBLEHOOK-KM14-D22	118×121×30	0,4
LOCKNUT-DOUBLEHOOK-KM15-D22	118×128×30	0,4

Mounting levers

Designation	Dimensions mm	Mass kg
LOCKNUT-DOUBLEHOOK.LEVER400	∅22×400	0,8

Adapters

Designation	Dimensions mm	Mass kg
LOCKNUT-DOUBLEHOOK.WRENCH-ADAPTER22-16	∅22×40	0,1

Accessories

Designation	Designation	Mass kg
ARCANOL-MOUNTINGPASTE-70G	Mounting paste	0,1



Only use FAG original accessories.

Appendix This appendix contains conversion formulae for using a torque wrench not supplied by us.

Conversion The following symbols are used in the formula, *Figure 14*.



Figure 14
Conversion

Torque to be set

$$M_{A2} = \frac{M_A \cdot l_1}{90 + l_1 - l_2}$$

M_{A2} Nm
Torque set on torque wrench

M_A Nm
Tightening torque, see *tables* from page 11

l_1 mm
Distance between centre of locking pin and centre of grip

l_2 mm
Key dimension, see certificate for torque wrench.

Notes

**Schaeffler Technologies
AG & Co. KG**

Postfach 1260
97419 Schweinfurt
Germany

Georg-Schäfer-Straße 30
97421 Schweinfurt
Germany

Phone +49 2407 9149-66

Fax +49 2407 9149-59

E-mail support.is@schaeffler.com

Internet www.schaeffler.com/services

Every care has been taken to ensure the correctness of the information contained in this publication but no liability can be accepted for any errors or omissions.

We reserve the right to make technical changes.

© Schaeffler Technologies AG & Co. KG

Issued: 2015, August

This publication or parts thereof may not be reproduced without our permission.

BA 28 GB-D